

**Drawings of Face Frame Inset applications**  
**Dibujos de aplicaciones internas para marco**

Select an inset style (P crank) hinge and the matching mounting plate thickness for your cabinet design.  
Seleccionar una bisagra (codo P) para puerta interna y el espesor de la base correspondiente para el diseño de su mueble.

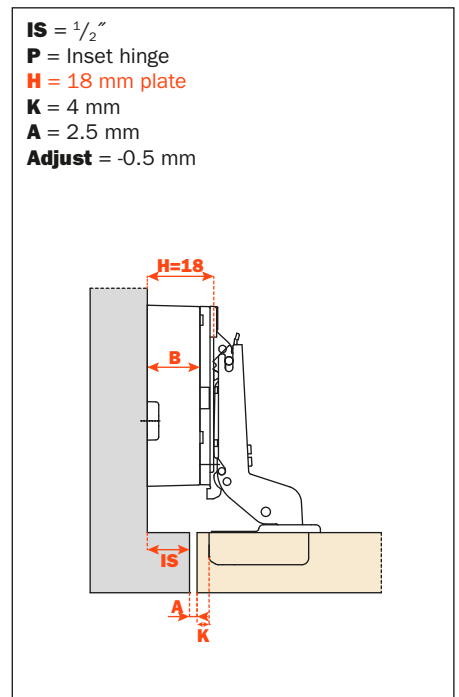
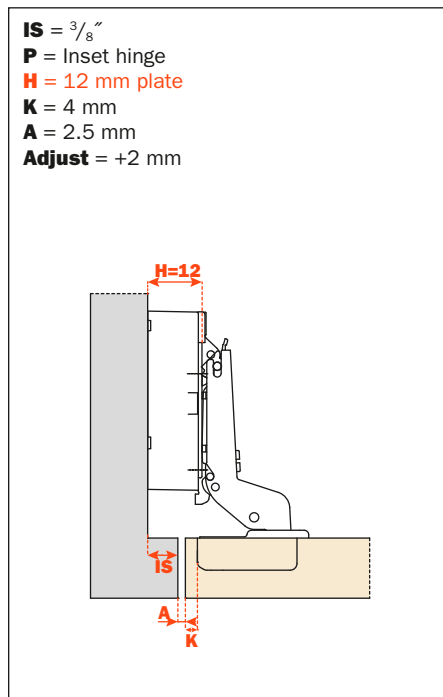
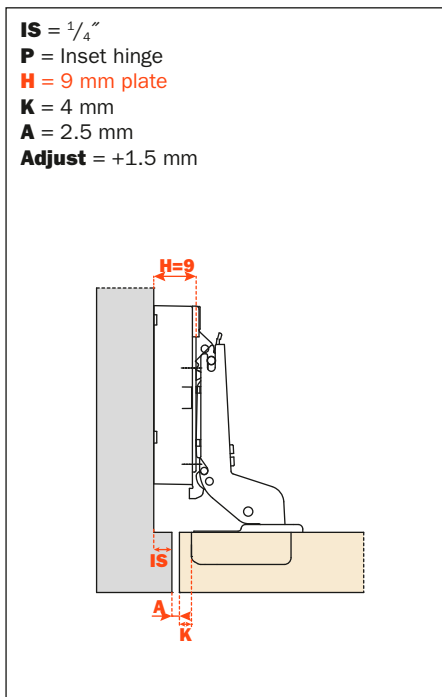
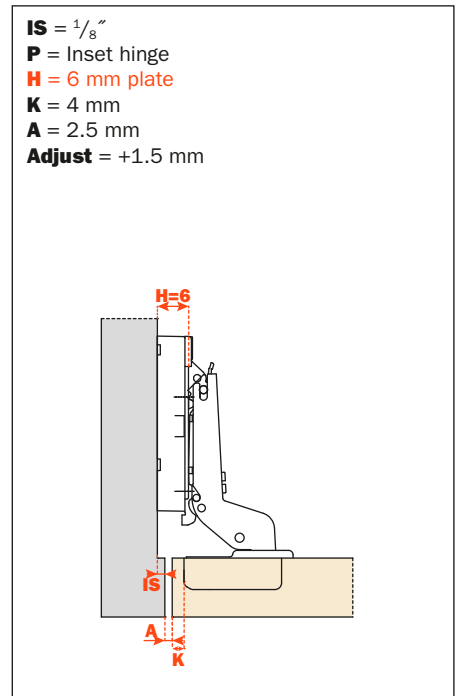
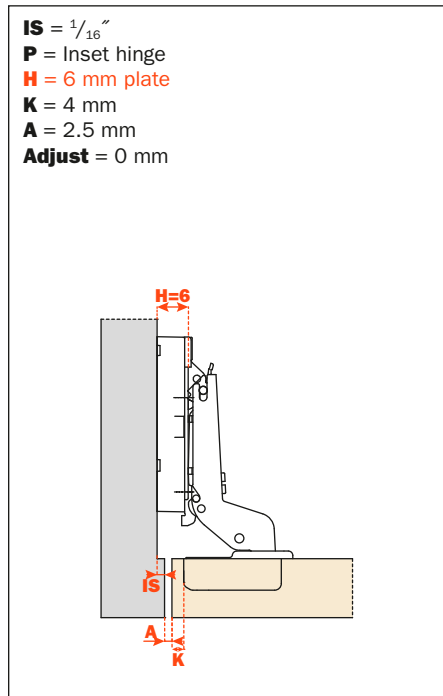
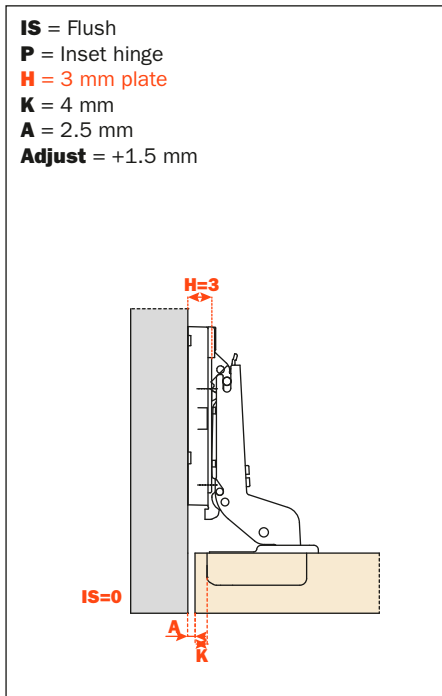

## Legend

- IS** = recess (from side to frame edge)
- B** = mounting plate
- H** = mounting plate thickness
- K** = edge bore distance
- A** = gap
- P** = crank inset hinge

## Abreviaciones

- IS** = distancia entre lateral y borde del marco
- B** = base
- H** = espesor de la base
- K** = distancia taladro borde externo
- A** = parte no cubierta del lateral
- P** = bisagra con codo para puertas internas

