

Drilling patterns - Standard face frame cabinet member

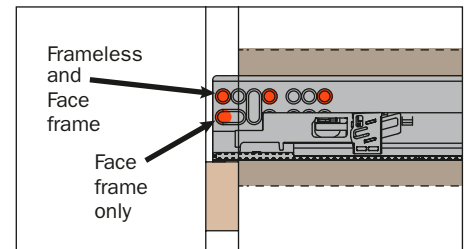

Note: orange dots indicate fixing screw locations and quantity to meet load ratings.

Mounting to the cabinet side - Runner lengths 381, 457 and 533 mm

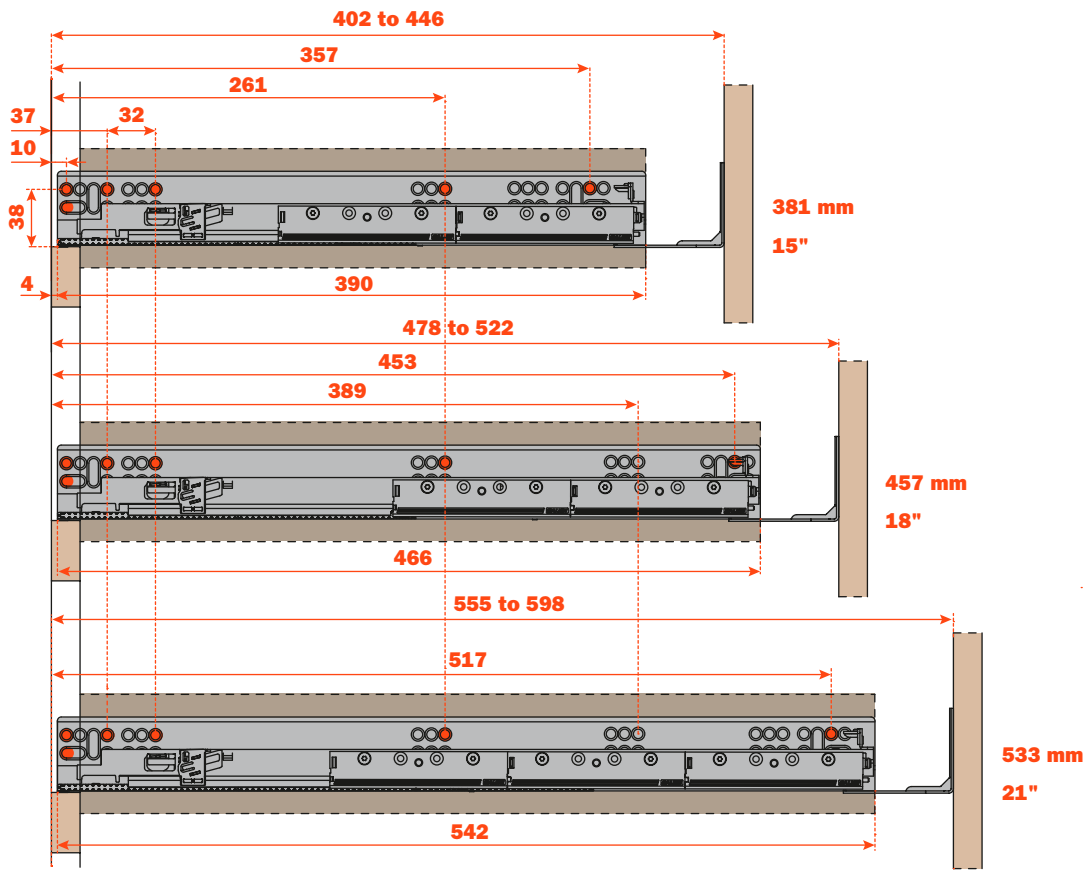
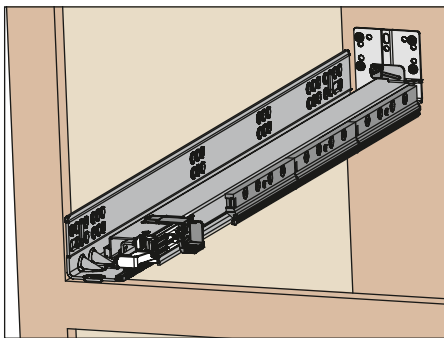

Face frame application without filler behind frame

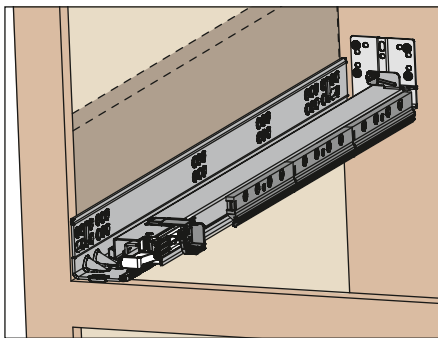

Face frame application with filler behind frame

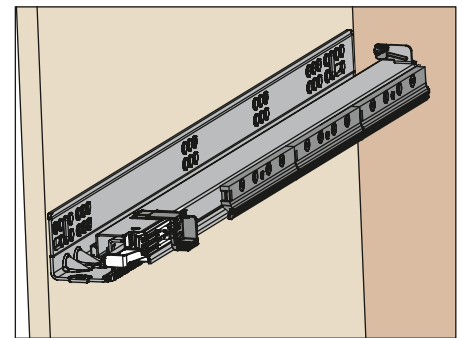

Frameless application

Use of rear sockets for any load above 75 Lbs is not recommended

Sockets and brackets can be used for the correct alignment of the runners before fixing to the cabinet side.

Drilling patterns - Short version cabinet member

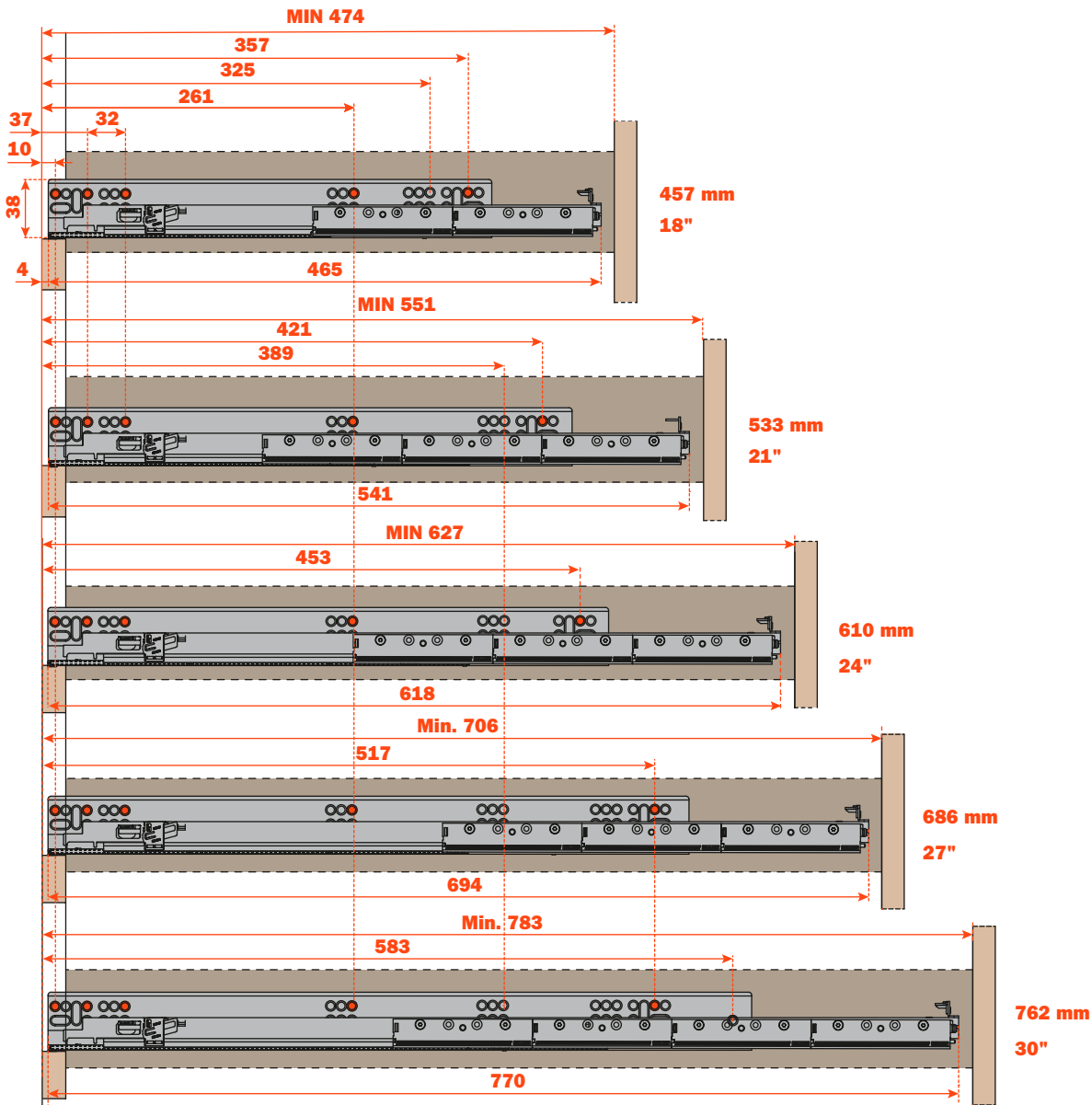

Note: orange dots indicate fixing screw locations and quantity to meet load ratings.

Mounting to the cabinet side - Runner lengths 457, 533, 610, 686 and 762 mm

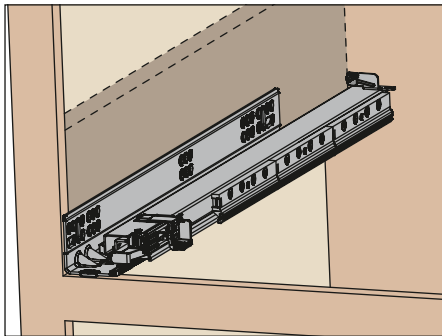

Face frame application with filler behind frame

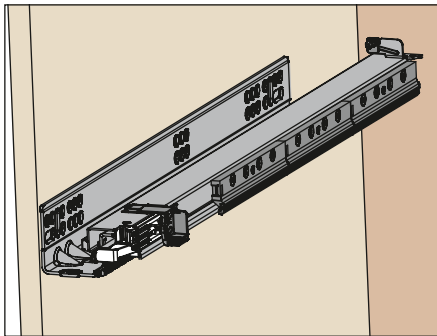

Frameless application

Use of at least 4 fixing screws to the side is highly recommended. For these runner lengths rear brackets and sockets cannot be used. Cabinet sides must be blocked. On longer lengths load capacity may vary.